

# LEGIBILITY NOTICE

A major purpose of the Technical Information Center is to provide the broadest dissemination possible of information contained in DOE's Research and Development Reports to business, industry, the academic community, and federal, state and local governments.

Although a small portion of this report is not reproducible, it is being made available to expedite the availability of information on the research discussed herein.

LA-UR--89-3297

DE90 002445

LA-UR-89-3297  
1989

Los Alamos National Laboratory is operated by the University of California for the United States Department of Energy under contract W 7405 ENG 36

**TITLE:** Optimization of the Testing Volumes with Respect to Neutron Flux Levels in the Two-Target High Flux D-Li Neutron Source for the International Fusion Materials Irradiation Facility

**AUTHORS:** William P. Kelleher and George L. Varsamis

**SUBMITTED TO:** IEEE 13th Symposium on Fusion Engineering  
October 2-6, 1989  
Knoxville, TN

**DISCLAIMER**

This report was prepared as an account of work sponsored by an agency of the United States Government. Neither the United States Government nor any agency thereof, nor any of their employees, makes any warranty, express or implied, or assumes any legal liability or responsibility for the accuracy, completeness, or usefulness of any information, apparatus, product, or process disclosed, or represents that its use would not infringe privately owned rights. Reference herein to any specific commercial product, process, or service by trade name, trademark, manufacturer, or otherwise does not necessarily constitute or imply its endorsement, recommendation, or favoring by the United States Government or any agency thereof. The views and opinions of authors expressed herein do not necessarily state or reflect those of the United States Government or any agency thereof.

This report is the property of the University of California. It is loaned to you for your personal use only. It is not to be distributed or reproduced without the express written permission of the University of California.

This report is the property of the University of California. It is loaned to you for your personal use only. It is not to be distributed or reproduced without the express written permission of the University of California.

**MASTER**



Los Alamos National Laboratory  
Los Alamos, New Mexico 87545

DISTRIBUTION OF THIS DOCUMENT IS UNLIMITED



**OPTIMIZATION OF THE TESTING VOLUMES WITH RESPECT TO NEUTRON  
FLUX LEVELS IN THE TWO-TARGET HIGH FLUX D-LI NEUTRON SOURCE  
FOR THE INTERNATIONAL FUSION MATERIALS IRRADIATION FACILITY**

**W. P. Kelleher  
A4, MS F611**

**G. L. Varsamis  
CTR12, MS F641**

**Los Alamos National Laboratory, Los Alamos, New Mexico 87545**

**ABSTRACT:** An economic and fusion-relevant source of high-energy neutrons is an essential element in the fusion nuclear technology and development program. This source can be generated by directing a high energy (30-40 MeV) deuteron beam onto a flowing liquid lithium target, producing neutrons via the D-Lithium stripping reaction. Previous work on this type of source concentrated on a design employing one deuteron beam of modest amperage (100 mA). This design was shown to have a relatively small testing volume with high flux gradients and was therefore considered somewhat unattractive from a materials testing standpoint. A design using two lithium targets and two high-amperage beams (250 mA) has recently been proposed. This two beam design has been examined in an effort to maximize the test volume while minimizing the flux gradients and minimizing the effect of radiation damage on one target due to the other. A spatial, energy and angle dependent neutron source modeling the D-Lithium source was developed. Using this source, a 3-dimensional map of uncollided flux within the test volume was calculated. The results showed that the target separation has little effect on the available experimental volume and that a testing volume of ~35 liters is available with a volume averaged flux above  $10^{14}$  n/cm<sup>2</sup>/s. The collided flux within the test volume was then determined by coupling the source model with a Monte Carlo code. The spectral effects of the high-energy tail in the flux were examined and evaluated as to possible effects on materials response. Calculations comparing the radiation damage to materials from the D-Lithium source to that caused by a standard DT fusion first-wall neutron flux spectrum showed that the number of appm and dpa, as well as the ratio appm/dpa and dpa/MW/m<sup>2</sup> are within 30% for the two sources. The overall results indicate that the D-Lithium source configuration examined, is an attractive candidate as a fusion materials irradiation and technology testing source.

## I. INTRODUCTION

A fusion neutron test source will provide key experimental and design relevant information necessary to meet the goals of the fusion technology and development program. Previous work on producing this test source has been concentrated on providing it by means of a high energy (30-40 MeV) deuteron beam impinging upon a flowing liquid lithium target, utilizing the D-Lithium stripping reaction [1]. The major drawback of that design was the relatively small testing volume (about 1.2 liters with neutron fluxes above  $10^{14}$  n/cm<sup>2</sup>/s) with high neutron flux gradients. Furthermore questions were raised as to the magnitude and impact of the high energy (above 14 MeV) neutrons generated in this approach.

An alternative design that addresses the first concern has recently been proposed [2]. The original concept, the Fusion Materials Irradiation Test (FMIT) facility, involved a single (100 mA) beam incident on a single lithium target [1]. The improved D-Lithium scheme recently proposed [2] involves two deuteron

beams incident on two lithium targets at right angles, arranged in the configuration shown in Fig. 1 [3]. The reference beam current is 250 mA on each target, thus significantly increasing the available materials-test volumes.

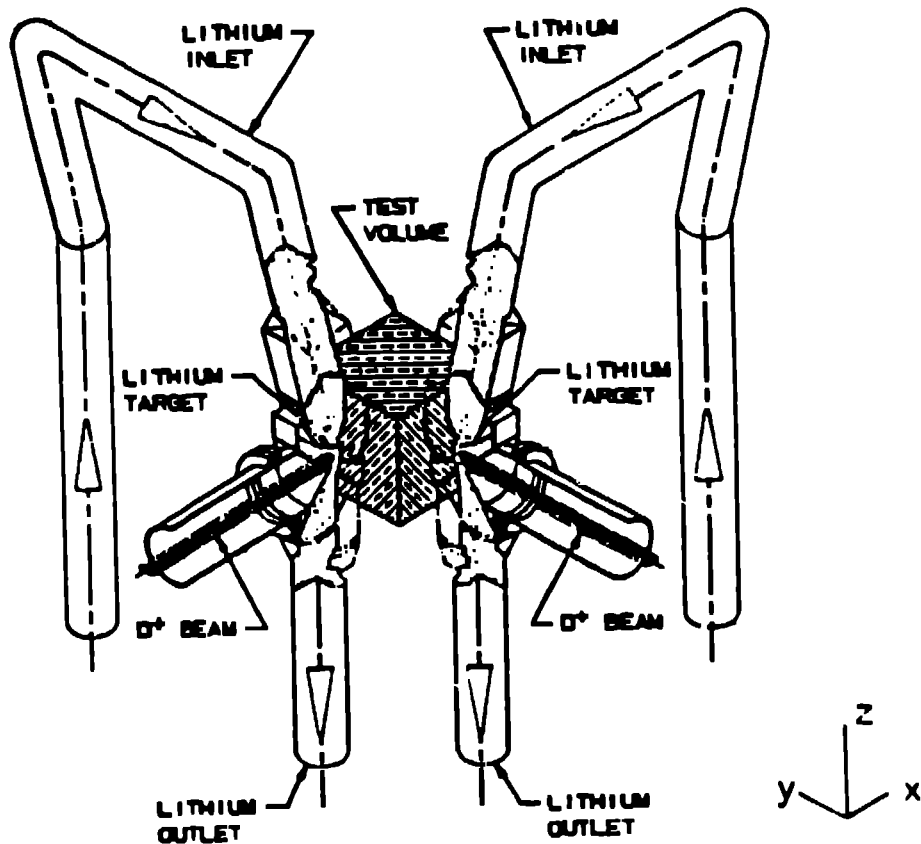

Figure 1. Schematic of the target and test zone for the D-Lithium source.

Figure 1 is an illustration of the target and sample-test region showing the two lithium jets oriented at right angle to each other and spaced about 10 cm from their common vertex. The viewing position is outside the shield wall, midway between the deuteron beams, and above the horizontal midplane. The lithium in each target flows into a jet-forming nozzle through a flow straightener to eliminate large scale turbulence. A 1.9 cm thick liquid-lithium jet exits the nozzle and flows along a curved thin steel wall, with its free surface exposed to the incident deuteron beam. The 35 MeV deuterons are completely stopped in the lithium and since only a small fraction produce neutrons, most of the energy is deposited in the jet. The centrifugal force introduced by the curved flow path (concave towards the beam) increases the internal pressure sufficiently in the jet to prevent local boiling at the point where the peak energy deposition occurs.

The two target/two beam D-Lithium concept was evaluated with an emphasis placed on optimizing neutronics performance with respect to target geometry, deuteron beam

characteristics, and thermal-hydraulics requirements. The results of the study [2,3] indicated that the two target geometry and modular accelerator system provides considerable flexibility in the achievable neutron-flux levels and test volumes, and also permits flux-gradient tailoring, staged expansion of testing capability, and improved facility availability.

The neutronics related results of these previous studies [2,3] were based on estimations of the uncollided neutron flux within the test volume. The next step in the evaluation of the neutronics performance of the D-Lithium source, involves estimates for the fully transported neutron flux in a test-specimen introduced in the testing volume, and subsequent calculation of appropriate materials response functions (such as damage and transmutations). This is an ongoing research, whose first results are reported herein.

The neutron source spectrum for the D-Lithium reactions includes contributions from the stripping reaction, the formation of a compound nucleus and other nuclear reactions. A spatial, energy and angle dependent neutron source model was developed with the methods presented in part II of this work. Part III presents the results of an analysis that maximizes the available test volume at given uncollided flux levels, by examining a range of beam/target/test-volume configurations. In part IV, the detailed neutron source model is coupled with a Monte Carlo code (MCNP) [4] to provide an energy-dependent point-wise neutron flux spectrum within the test volume. Materials response functions (dpa and appm) are subsequently estimated based on the fully transported flux, and compared to those from a typical DT fusion first-wall spectrum. Finally some conclusions are drawn.

## II. SOURCE DESCRIPTION

The doubly differential yield per microcoulomb of beam charge is shown in Figure 2.

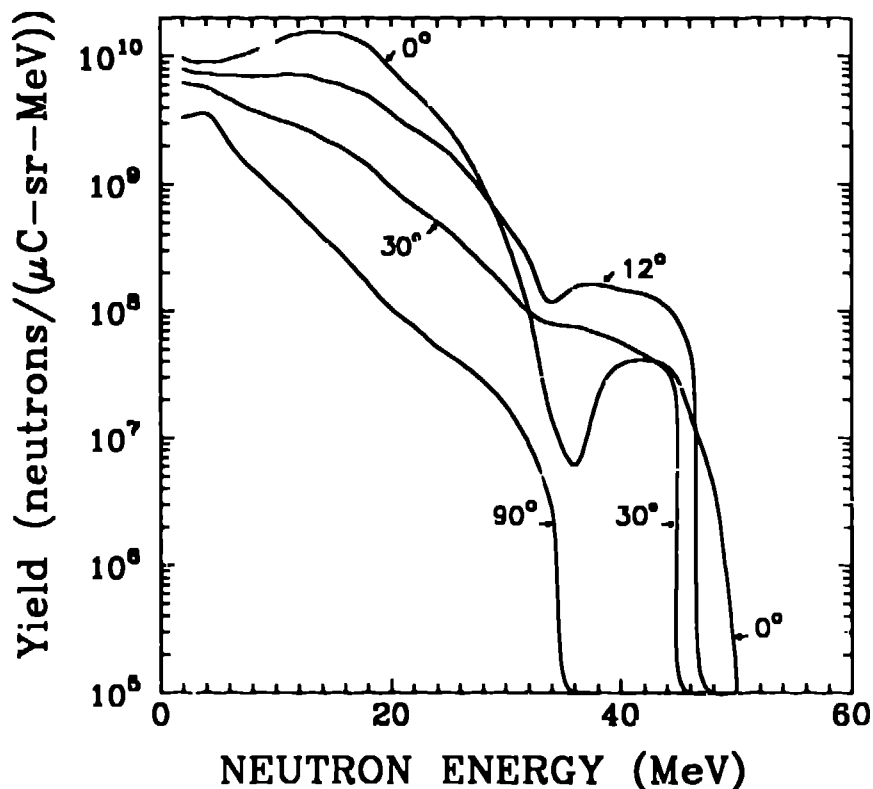

Figure 2. Doubly differential neutron yield for 35 MeV deuterons incident on a thick lithium target. The units are in terms of neutrons per microcoulomb of beam charge per steradian per MeV of neutron energy.

This yield is for a thick lithium target; that is a target which completely stops all of the deuterons. The yield is plotted for 0°, 12°, 30°, and 90° directions, where the angle is measured with respect to the beam axis. This data was generated by using a computer code developed by workers at Hanford Engineering Development Laboratory (HEDL) and is based on experimental measurements done by the HEDL workers [8]. This code provides a good fit to most of the experimental data and can be used to generate the thin target yield; giving in essence, a doubly differential cross section for the D-Li neutron producing reaction, depending on deuteron energy,  $E_d$ , neutron energy,  $E_n$ , and angle,  $\theta$ . Referring to Figure 2, notice that the forward yield curves have a 'shoulder' starting at ~35 MeV. This shoulder shape of the forward yield is not predicted by the Serber [7] model often used to describe the  $D+Li$  reaction, and may be due to the  $^7Li(d,p)^6He$  reaction. Further, the total forward Serber yield tends to be ~5-10 times smaller than forward yield based on

experimental data. From this it can be concluded that the D-Li reaction is more complicated than the Serber model predicts. The Serber model was derived in a classical manner for very high energy deuterons ( $> 100$  MeV) and probably is not accurate for deuterons in the 0-35 MeV energy range. The highly forward peaked behavior of the yield dictates that the source be modeled with a very fine division of angular bins. Also, the forward yield depends strongly on the deuteron energy in the target, which in turn depends on the penetration distance of the beam into the target. Consequentially, to model the source accurately, the source must be described with three variables: distance into the target,  $X$ , angle from the beam axis,  $\theta$ , and neutron energy,  $E_n$ . The source was modeled using a  $\Delta E_d$  corresponding to every 1 mm of target penetration, a  $\Delta\theta$  of  $2.5^\circ$ , and a  $\Delta E_n$  of 2 MeV. To model the neutron transport in the test cell, it was decided that the continuous-energy/continuous-angle Monte Carlo code, MCNP, was the best tool for the job, based on the following reasons:

(1) The highly angular source dependence would lead to an excessively complex quadrature set in a 2-d or 3-d discrete ordinates code.

(2) The high energy ( $\leq 100$  MeV) cross sections for the proposed test cell materials have been developed for MCNP and benchmarked [5].

Under current limitations within MCNP, the source can be modeled with one level of dependence; that is the dependent variables in the source must depend directly on an independent variable. However, the D-Lithium source has two levels of dependency: the neutron energy,  $E_d$ , depends on the angle,  $\theta$ , which in turn depends on the independent variable,  $X$ . To accommodate the D-Li source, a special version of MCNP was developed. Further, because of the detailed nature of the source and the resulting size of the MCNP input file, a code was written to produce the MCNP input file for a given beam geometry and energy. This code provides for biasing the angle, the neutron energy and the spatial parameters of the source. In particular, the  $y$  and  $z$  spatial dependence of the source (beam cross section) was modeled with  $\sim 1500$  points. The resulting source is described by millions of discrete probability bins. Therefore, the MCNP computer runs had to be done with millions of source particles to adequately sample the source.

### III. UNCOLLIDED FLUX RESULTS

The detailed source model presented in section II was used to obtain a point-wise uncollided flux for the two target / two beam configuration, within a cubic test cell having a volume of 64 liters. By varying the spacing between the targets, the analysis was repeated for various target configurations in an effort to maximize the available testing volume at specific uncollided flux levels.

In Figure 3, the calculated testing volume is plotted against the volume averaged neutron flux for target separations of 10 cm and 20 cm, where the target separation is defined as the



distance in the x-y plane of each beam centerline from their common vertex. The minimum value of flux within the same volume was also calculated, and was found to be lower than the volume averaged flux values by factors of 2-3. For example, for a target separation of 20 cm, the volume with a minimum flux above  $10^{14}$  n/cm<sup>2</sup>/s is 93 liters, while the volume averaged flux within that same volume is  $2 \times 10^{14}$  n/cm<sup>2</sup>/s.

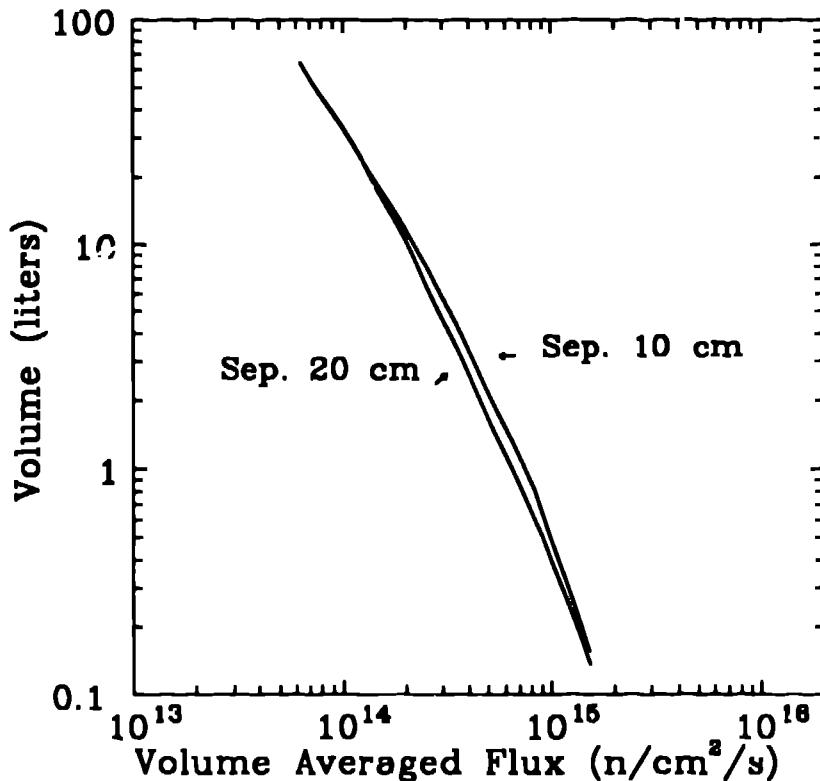

Figure 3. Experimental volume versus uncollided volume averaged flux at various target separations for the reference design (two targets / two beams at 250 mA each).

Figure 3 also shows that the target separation has little effect on the experimental volume at specific volume averaged flux levels. In general, increasing the target separation slightly increases the available testing volume at low to medium flux levels, while decreasing the volume at high flux levels (above  $10^{15}$  n/cm<sup>2</sup>/s). Consequentially, the determining factor in fixing the target separation is the radiation and heat flux damage seen by one target due to the other. For these reasons, the design hereafter referred to as the "reference design" will have the two targets spaced 20 cm from their common vertex, with each beam carrying 250 mA.

Figure 4 shows the flux contours at the face of one of the two targets for the reference design. The flux contours define surfaces that enclose points with a flux greater than or equal to the flux level given on the contour. The elliptical shape

of the flux contours is produced by the asymmetry of the deuteron beam. The beam in the z-direction is Gaussian with a standard deviation of 1 cm, while in the y-direction it exhibits a 4 cm wide flat-top, having Gaussian tails with a standard deviation of 1 cm at each side.

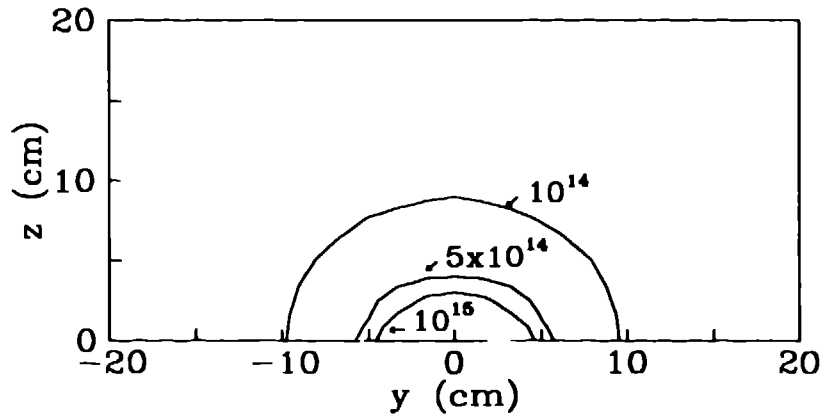

Figure 4. Uncollided flux contours at the face of one target for the reference design.

Figure 5 shows the flux contours for the reference design at the  $z=0$  plane; this plane is perpendicular to the two lithium flow tubes(see Figure 1). The surface that encloses all of the points in the test cell with a flux level of  $10^{14}$  n/cm<sup>2</sup>/s or greater is shown in Figure 6. The volume enveloped by this surface is 9.3 liters.

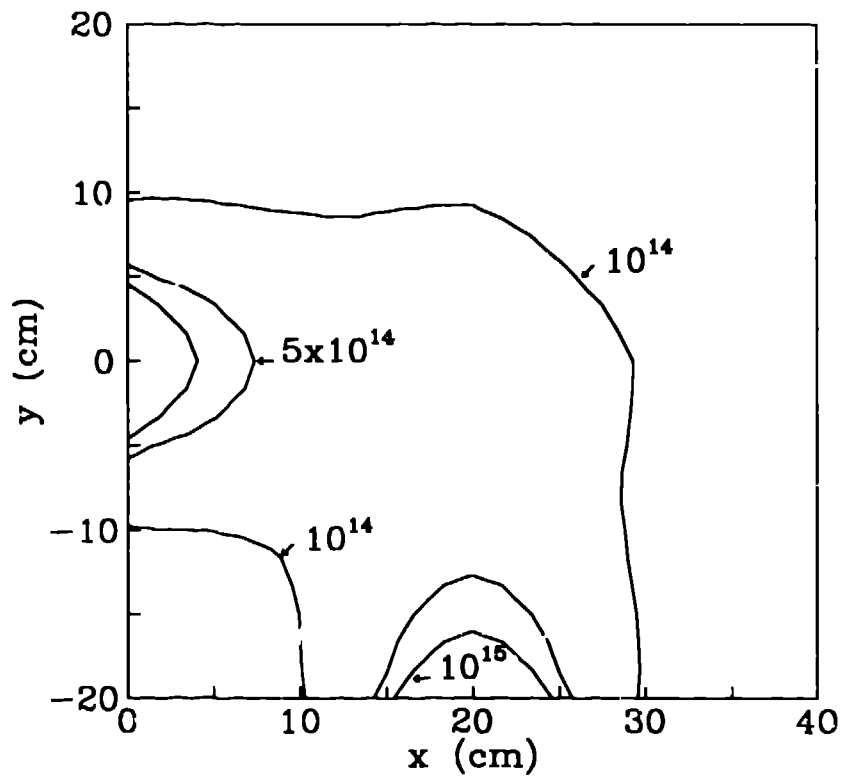

Figure 5. Uncollided flux contours at the  $z=0$  plane for the reference design.

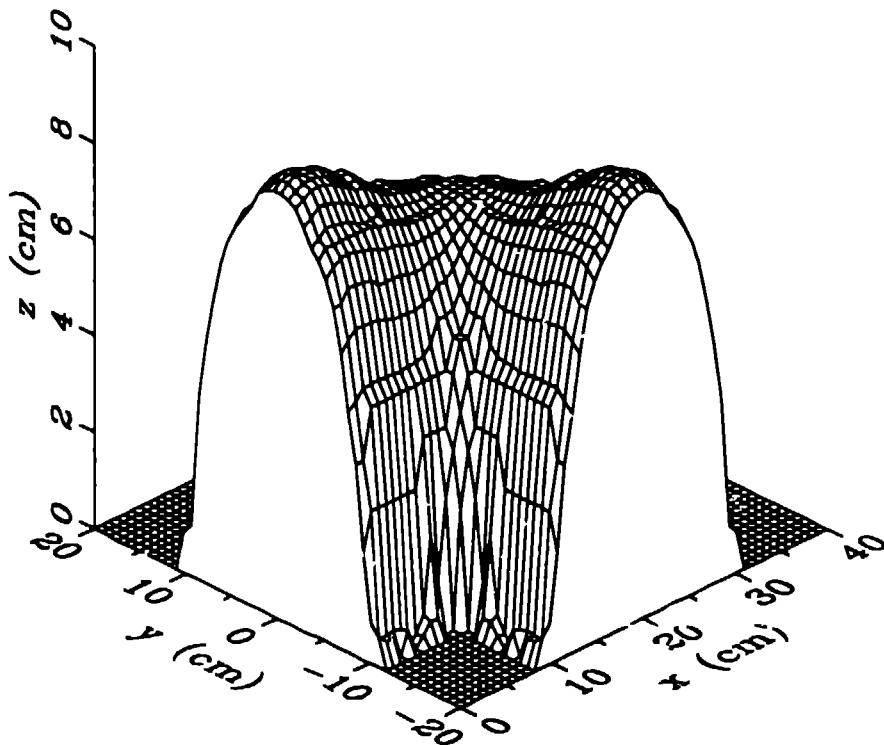

Figure 6. Surface enclosing points with uncollided flux greater or equal to  $10^{14}$  n/cm<sup>2</sup>/s.

An examination of Figures 4 and 5 show that points in the test region close to the target are exposed to very high fluxes and rather steep flux gradients. However, there is ~35 liters of test volume having a volume averaged flux of  $10^{14}$  n/cm<sup>2</sup>/s which has relatively low flux gradients.

#### IV. NEUTRON TRANSPORT RESULTS

The detailed neutron source model presented in part II was coupled with a Monte Carlo code (MCNP), to evaluate the fully transported flux within the test cell. A potentially serious problem with this coupling is that the cross section data implemented in the latest MCNP version are based on ENDF-B/V evaluated data and extend to neutron energies of up to 20 MeV only. The neutrons produced from the D-Lithium reaction have energies as high as 50 MeV. For this reason a modified MCNP version was used [5], that includes cross section libraries with data up to 100 MeV for some materials (including H, O and Fe).

The analysis examined a geometric representation of a one beam / one target design. The two target / two beam system is symmetric with respect to the diagonal in the x-y plane. Accordingly, the two target / two beam results can be easily

obtained by superposition of two one-target results, with one of the two data sets appropriately rotated. The geometric simulation closely resembles the arrangement shown in Figure 1. The test region is simulated with a 40 cm cube of a homogeneous material containing 50 % (volume) iron, 30 % (volume) water and 20 % (volume) void. This material represents an average "cooled test specimen" where the void is introduced by the existence of the cooling tubes.

The point-wise flux estimates were determined by computing volume averaged fluxes in small test volumes at various positions within the test cell region. The average mean free path of the neutrons in the test cell material is ~3.4 cm. The size of a side of the cubic test volumes was chosen to be approximately one-half of a mean free path, or 2 cm. The complete test cell is a cube with a side of 40 cm. Consequentially, there are ~10 mean free paths between the back wall and the last point where flux is calculated. The 40 cm volume was separated into twenty 2 cm-per-side cubic cells. In each cell the flux was estimated in twenty-five 2 MeV bins starting at zero MeV. In an effort to improve the uncertainties in the estimated flux, the cell importances were chosen so that the total neutron population in each cell was held constant.

#### **A. Effect of High Energy ( $\geq 20$ MeV) Cross Sections.**

The current public version of MCNP [4] uses neutron cross section libraries that include all relevant neutron reactions up to 20 MeV in neutron energy. The modified MCNP version used for these calculations [5] includes neutron cross sections up to 100 MeV for selected materials, and the specially developed source dependence discussed in section II. It is expected that the greatest contribution of the high-energy tail in the D-Lithium reaction spectrum will be in the forward direction, and will peak at the beam centerline direction.

The neutron flux at 20 points (every 2 cm) along the beam centerline (x-direction in the simulation utilized) was calculated with both MCNP versions, to compare the effect of the high-energy cross sections. The results were for all practical purposes the same, except at distances far away from the source. This can be explained by the shape of the cross sections above 20 MeV. The MCNP public code assumes that the values of the cross sections above 20 MeV are constant, which is essentially true for the materials of interest for this study. In addition, it is expected that most of the neutron transport occurs at relatively low energies, thus minimizing the effects of the high-energy tail. Nevertheless, for the remainder of the calculations reported herein, the MCNP version which includes the high-energy cross sections was used.

#### **B. Comparison of D-Lithium and standard fusion DT neutron spectra.**

For a given unit neutron flux, the materials response functions can vary widely depending on the energy differential flux spectrum. Accordingly, the resulting damage produced by a unit flux will be a function of the shape of the spectrum.

Consequentially, it is useful to have a comparison between the D-Lithium source spectrum and the spectrum produced within the same test-specimen from a monoenergetic 14 MeV DT neutron source. Using MCNP, the neutron energy dependent flux was calculated at points within the test cell along the centerline of the beam and the results were normalized to the same total flux.

Neutron spectra were estimated for three different cases: (1) a monoenergetic 14 MeV neutron source simulating a DT fusion reactor first-wall environment; (2) the spectrum from the D-Lithium source as it is estimated from the uncollided-flux analysis presented in part III of the present report; and (3) the fully transported flux from the D-Lithium source. Figures 7 and 8 show the results of these calculations at distances of 1 cm and 20 cm within the test specimen, respectively.

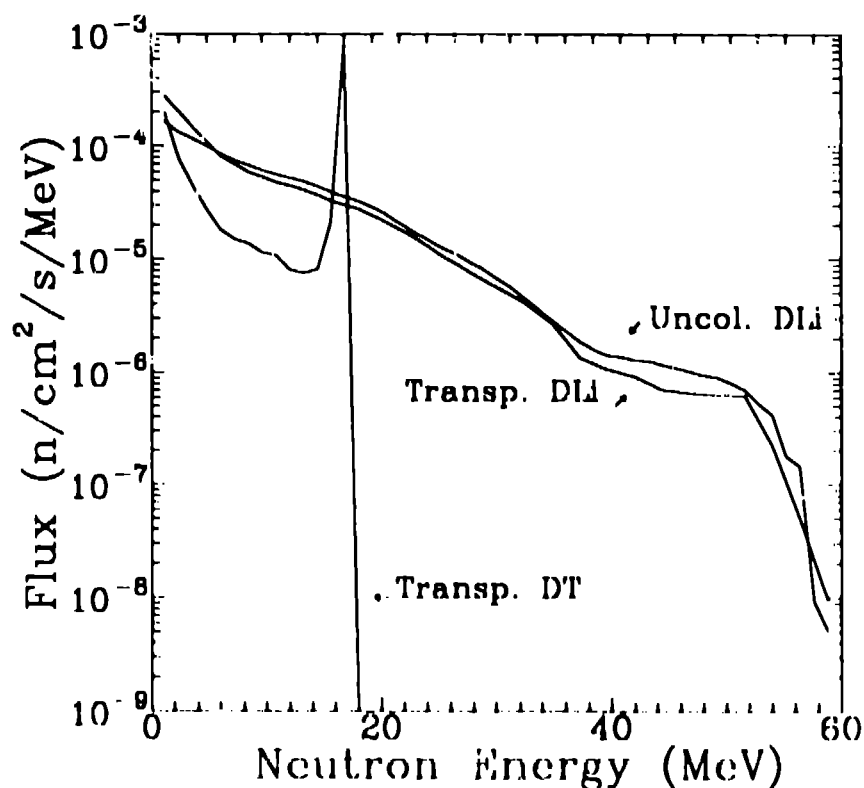

Figure 7. Neutron flux spectrum comparison between a 14 MeV source and the D-Lithium source at a distance of 1 cm (at the beam centerline position) away from the target back wall and within the test specimen.

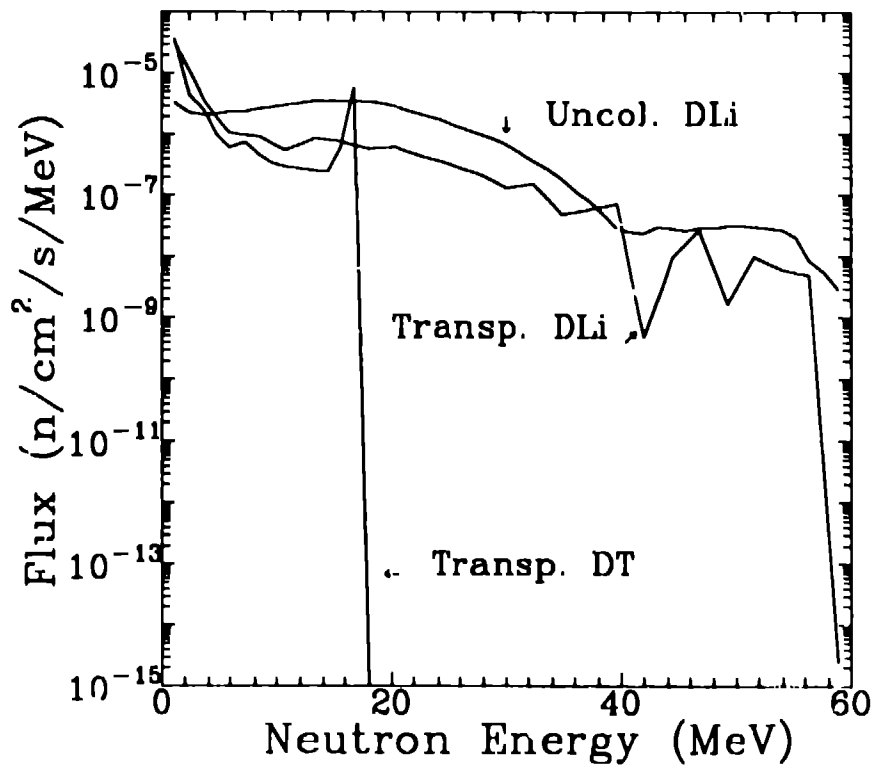

Figure 8 Neutron flux spectrum comparison between a 14 MeV source and the D-Lithium source at a distance of 20 cm (at the beam centerline position) away from the target back wall and within the test specimen.

The results shown in Figure 7 are an indication of the flux behavior very close to the source, since they are calculated at a point that is separated from the source by a 0.16 cm thick stainless steel (iron) wall. The 14 MeV spectrum exhibits a very profound peak at 14 MeV; this peak is due to the contribution of the neutrons which have not yet had a collision. Also, there is little difference between the D-Lithium source collided and uncollided spectra: implying that there is very little backscattering in this region. From a materials response functions point of view the two spectra (14 MeV source versus D-Lithium source) are clearly different. The effect of these differences is determined in the subsequent analysis.

The results shown in Figure 8 exhibit the same general behavior, although the 14 MeV peak is not so pronounced any more, and the difference between the uncollided and the fully transported flux for the D-Lithium source is greater at the low energies. A similar analysis using MCNP was performed for the original FME design [6], without the use of high energy cross sections. As with the present work, the results from that analysis indicated that there are only small differences between the uncollided and the fully transported flux from the D

Lithium source. Therefore, using the uncollided flux to estimate available testing volumes (as was done in section III, and in previous studies [2,3]) will yield a fairly good estimate of the collided flux results.

### **C. Materials response functions.**

It is envisioned that the most important application of the D-Lithium source will be its use as a materials testing and qualification facility for fusion devices. It is prudent then to compare the damage to materials from the D-Lithium spectrum with that from a standard DT fusion first wall spectrum. For this analysis the results shown in Figures 7 and 8 are used.

A critical issue for the comparison is the choice of the testing material. The test specimen used in the flux studies presented above was based on iron, since the high-energy cross sections for that material were available in the modified version of MCNP that was utilized. Unfortunately the damage cross section data for iron are not fully known to high energies. On the contrary such data exist for copper [3] to energies as high as 50 MeV. For this reason the damage analysis was performed on copper. Based on a comparison of the copper and iron cross sections, it is expected that the transported flux in a copper-based test specimen is very similar to that of an iron-based test specimen. Consequentially, there should be little error in substituting the flux transported in iron for the flux transported in copper.

The materials response functions that are important to fusion reactor design are neutron damage to the material lattice and the production of transmutation isotopes, most important of which is Helium, He. In this work the neutron damage to the lattice was estimated using displacements per atom, dpa. The He production is measured in atomic parts per million, appm. Other derivative response functions are the ratio of appm to dpa and the dpa production per an equivalent neutron wall loading, WL, of 1 MW/m<sup>2</sup>.

Table I summarizes the results for the damage to copper as determined at two positions within the test cell: 1 cm away and 20 cm away from the target back-wall, along the beam centerline. These calculations were done for both a typical DT fusion neutron source and the DLithium source. The table also includes the ratios of the damage response functions between the two sources.



Table I. Comparison of damage to materials between the D-Lithium source and a standard DT fusion neutron source.

For a point 1 cm into the test cell

Quantity	DLi	DT	DLi/DT
WL (MW/m <sup>2</sup> )	23.9	33.4	0.71
<En> (MeV)	7.3	10.3	0.71
dpa	139.3	179.6	0.77
appm (He)	1149	1888	0.61
dpa/(MW/m <sup>2</sup> )	5.8	5.4	1.09
appm/dpa	8.2	10.5	0.78

For a point 20 cm into the test cell

Quantity	DLi	DT	DLi/DT
WL (MW/m <sup>2</sup> )	1.18	0.84	1.38
<En> (MeV)	4.4	3.1	1.38
dpa	7.8	6.4	1.19
appm (He)	52.4	32.2	1.63
dpa/(MW/m <sup>2</sup> )	6.5	7.6	0.85
appm/dpa	6.8	4.9	1.37

Table I indicates that although the two source spectra are different, the damage to materials is similar. Because the points reported in Table I represent points along the beam centerline, it is expected that these points will reflect the maximum differences in the two source spectra. Moreover, if one takes into account the uncertainties involved in the calculations related to cross-sections, computer codes, and exact irradiation scenarios, it can be concluded that the damage to a material exposed to a fusion first-wall/blanket neutron spectrum can be reasonably simulated with a D-Lithium based testing facility.

## V. CONCLUSIONS

Neutronics analysis for a two target, two beam neutron source based on the D-Lithium reaction was presented. A detailed spatial, energy and angle dependent neutron source model was developed, which properly accounts for the contributions of all reactions involved in the DLi reaction process. The model was used to optimize the available testing volume at specific flux levels, by examining a range of beam/target configurations. It was observed that the target separation (defined as the distance between the beam centerline to the common vertex of the two targets) has little effect on the available experimental volume. Testing volumes of a few tens of liters are available with volume averaged flux levels above  $10^{14}$  n/cm<sup>2</sup>/s.

The same source model was subsequently coupled with a Monte Carlo code (MCNP) to estimate the fully transported flux spectrum within the test cell. This spectrum is somewhat different from a typical DT fusion first wall/blanket neutron

spectrum. However, the results indicated that the damage to materials from the D-Lithium source is similar to that of the typical D-T source examined under the same conditions (damage to the same material at the same point within the test cell). The number of appm and dpa, as well as the ratio appm/dpa and dpa/MW/m<sup>2</sup> are within 30% for the two sources. It is noted that the points examined lie in the test cell along the beam centerline, and were expected to yield the maximum differences between the two sources. It can then be reasonably concluded that the two-target, high-beam current D-Lithium source is a technologically and economically attractive candidate as a fusion materials irradiation and technology testing source.

#### ACKNOWLEDGEMENTS

The authors would like to thank R. Schrandt of Los Alamos (X-6) for his efforts in modifying MCNP. Also, the authors would like to thank F. Mann of HEDL for the very useful consultations. This work was supported by the US DOE. One of the authors (G. L. Varsamis) was supported in part by an appointment to the US DOE Fusion-Energy Post Doctoral Research Program administered by Oak Ridge Associated Universities.

## REFERENCES

- [1.] A. L. Trego et al., "Fusion Materials Irradiation Test Facility - A Facility for Fusion Materials Qualification," Nuclear Technology/Fusion, vol. 4, p 695 (1983).
- [2.] G. P. Lawrence et al., "High-performance Deuterium-Lithium Neutron Source for Fusion Materials and Technology Testing," Proc. 1989 Particle Accelerator Conference, Chicago, IL, March 20-23.
- [3.] G. L. Varsamis et al., "Conceptual Design of a High-Performance D-Lithium Neutron Source for Fusion Materials and Technology Testing," submitted to Nuc. Sci. Eng., 1989.
- [4.] J. F. Briesmeister, ed., "MCNP-A General Monte Carlo Code for Neutron and Photon Transport, Version 3A," report LA-7396-M, Rev. 2, Los Alamos National Laboratory, 1986.
- [5.] W. B. Wilson et al., "Use of GNASH Based Cross-Section Data in the Description of 75-MeV P+CU Thick-Target Neutrons and Their Transmission Through Concrete, With Comparison to Measured Data," Proc. of Adv. in Nucl. Eng. Comp. and Rad. Shield, Santa Fe, NM, April 9-13, 1989.
- [6.] J. O. Schiffgens et al., "Spatial Variations of Damage Parameters in FMIT and their Implications," Jou. Nuc. Mat., 85 & 86, pp 491-495 (1979).
- [7.] R. Serber, "The Production of High Energy Neutrons by Stripping," Phys. Rev. 72 (1947) 1008.
- [8.] D. L. Johnson et al., "Measurements and Calculations of Neutron Spectra From 35 MeV Deuterons on Thick Lithium for the FMIT Facility," Journal of Nuclear Materials 85&86 (1979) 467.